

ELECTRONIC VISIONS, INC.

PC-LOG 2

PC-LOG 2

PC-LOG 2 is an Electronic Visions, Inc. product which replaces serial terminals and/or logging devices with an intelligent micro-computer interface. Data normally lost on conventional terminals is now captured and recorded to disk or WORM -based log files. The voluminous amounts of paper generated by hardcopy logging devices is eliminated. PC-LOG allows rapid location of important messages by providing review and search capabilities. Archiving is supported through disk copies of log files.

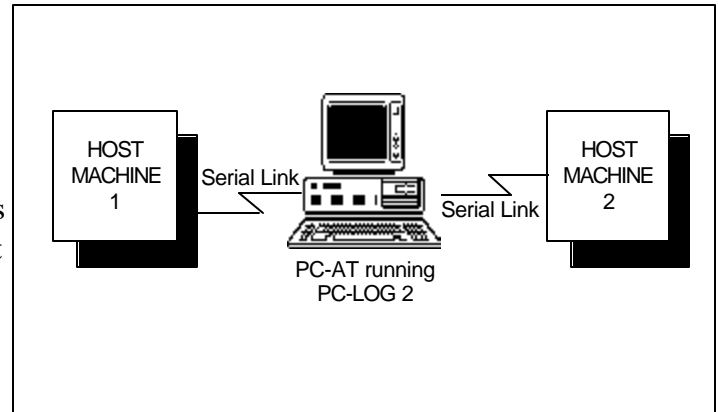

Figure 1, Typical PC-LOG 2 Connection

FEATURES

- » Connect to two different host systems
- » Log each host's messages to separate, local disk files
- » Review and search any log file while logging continues (including the ACTIVE log files)
- » Copy log files to removable media
- » Set Date and Time in the PC from the Host System and enter Date and Time on the Host system.
- » Context sensitive help
- » Keeps either reusable weekly log files (SUN.LOG through SAT.LOG) or daily log files (90JUL17.LOG)
- » Data rates of up to 19.2K baud with or without flow control
- » Software (XON/XOFF) or hardware flow control
- » Blank line and trailing blank suppression
- » Simulated full/half duplex operation
- » Change local time and date
- » Automatically uses text display modes up to 132 columns by 60 lines
- » Automatically respond to MODCOMP reboot

sequence. (H04, GO, /Date, /Time)

CONFIGURATION

- » Each host session is separately configurable
- » Serial communication parameters
- » Logging behavior
- » File transfer communication parameters
- » User interface behavior
- » Shift lock states
- » Screen colors

REQUIREMENTS

- » IBM® PC-AT or 100% Compatible with a fixed disk drive and 1 Serial port (2 ports for multiple host sessions or protocol transfers)
- » DOS 3.x (DOS 4.x if log files are to exceed 32mb in size)

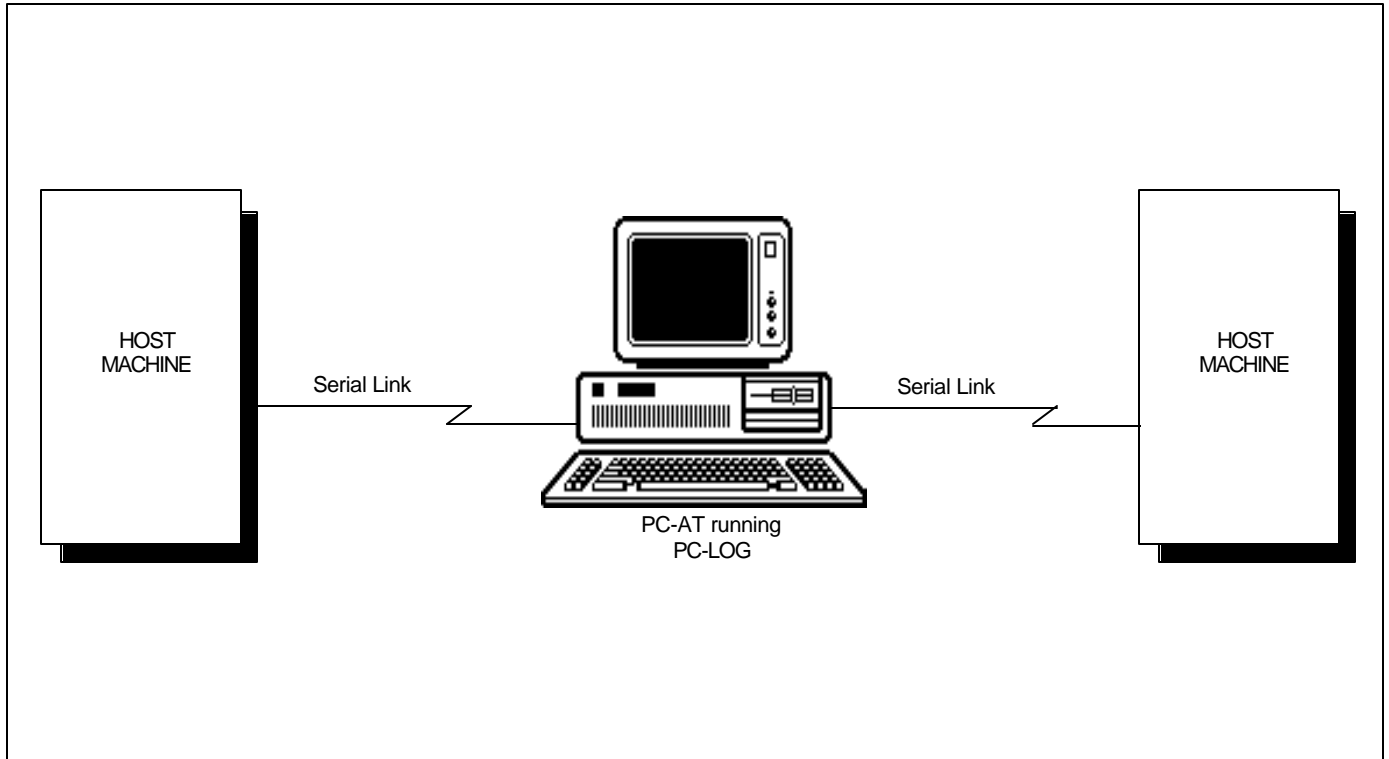

Figure 2, Typical PC-LOG Connection

Electronic Visions, Inc's products are of the highest quality and designed with the customers needs in mind. All products are delivered with a one year, return to factory warranty.

If you would like more information on this or any of the other products offered by Electronic Visions, Inc. please contact us at any of our offices listed.

World Headquarters
Electronic Visions, Inc.
1555 Magnolia St NE
Palm Bay, FL 32905
Voice: (321) 632-7530
<http://www.e-visions.com>

IBM is a registered trademark of International Business Machines, Inc.
PC-AT is a trademark of International Business Machines, Inc.
PC-LOG is a trademark of Electronic Visions, Inc.